

35+
Years

TEC.MO.®

UPH-70

PLASMA CUTTING TORCHES

AIRONCUT®

New high visibility consumable system
to cut inaccessible parts.

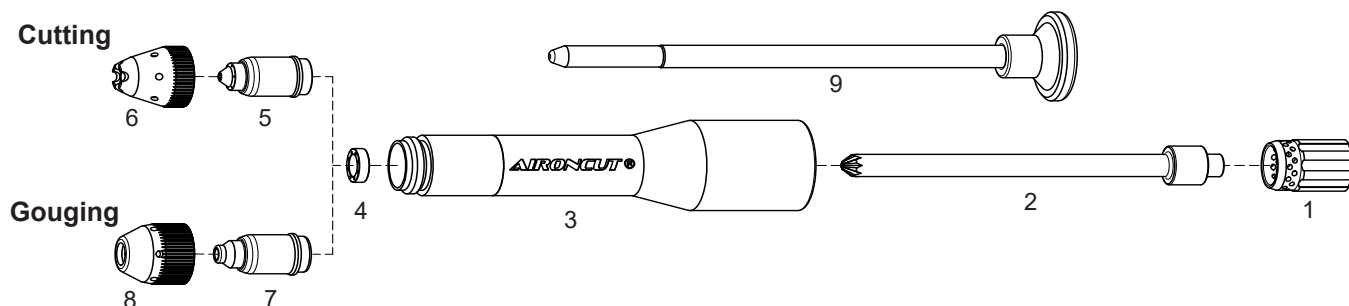

For gouging use maximum 4 bar

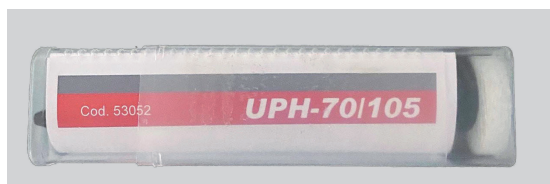
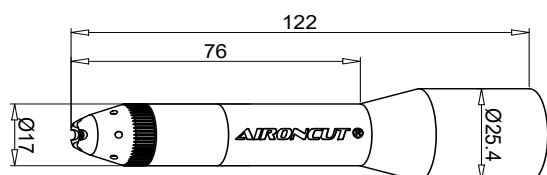
**53052 Standard Kit 70A Cutting**

#	Code	Description	Pkg
1	60041E	Swirl Ring 20-70A	2
2	53001	Electrode	3
3	53012	Shield Cup Body	1
4	53022	Vortex Ring	3
5	53031	Tip 20-45A	5
	53032	Tip 70A	5
6	53047	Shield Cap Cutting	5
7	53036	Tip 50A Gouging	5
	53037	Tip 70A Gouging	5
8	53046	Shield Cap Gouging	5
9	53080	Extractor for tip	1

BXAUPH70-AC**BXAUPH70-AC****Special Box**

Code	Description	Qty
60041E	Swirl Ring 20-70A	1
53001	Electrode	2
53022	Vortex Ring	2
53031	Tip 20-45A	3
53032	Tip 70A	5
53047	Shield Cap Cutting	2
53036	Tip 50A Gouging	3
53037	Tip 70A Gouging	5
53046	Shield Cap Gouging	2
53052	Standard Kit 70A Cutting	1

IT Util. Pat. Pend.:
N° IT202021000001583

45A Max Thickness 8 mm
70A Max Thickness 12.5 mm

35+
Years

TEC.MO.®

UPH-70

PLASMA CUTTING TORCHES

AIRONCUT®

**New high visibility consumable system
to cut inaccessible parts.**



35+
Years

TEC.MO.®

UPH-105

PLASMA CUTTING TORCHES

AIRONCUT®

New high visibility consumable system
to cut inaccessible parts.

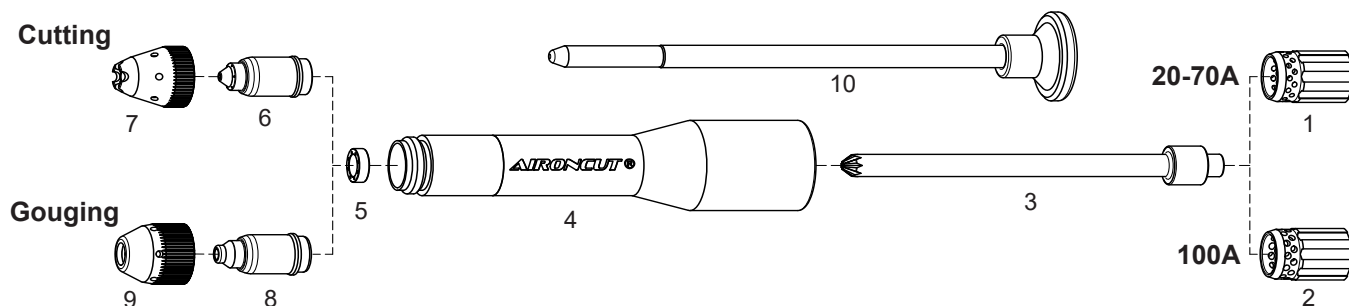

For gouging use maximum 4 bar

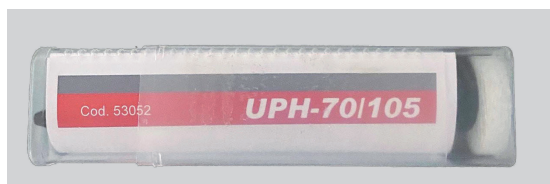
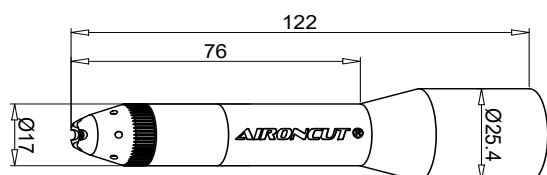
**53052 Standard Kit 70A Cutting**

#	Code	Description	Pkg
1	60041E	Swirl Ring 20-70A	2
2	60024E	Swirl Ring 100A	2
3	53001	Electrode	3
4	53012	Shield Cup Body	1
5	53022	Vortex Ring	3
6	53031	Tip 20-45A	5
	53032	Tip 70A	5
	53034	Tip 100A	5
7	53047	Shield Cap Cutting	5
8	53036	Tip 50A Gouging	5
	53037	Tip 70A Gouging	5
	53038	Tip 100A Gouging	5
9	53046	Shield Cap Gouging	5
10	53080	Extractor for tip	1

BXAUPH105-AC**BXAUPH105-AC****Special Box**

Code	Description	Qty
60041E	Swirl Ring 20-70A	1
60024E	Swirl Ring 100A	1
53001	Electrode	2
53022	Vortex Ring	2
53031	Tip 20-45A	3
53032	Tip 70A	3
53034	Tip 100A	5
53047	Shield Cap Cutting	2
53037	Tip 70A Gouging	3
53038	Tip 100A Gouging	5
53046	Shield Cap Gouging	2
53052	Standard Kit 70A Cutting	1

IT Util. Pat. Pend.:
N° IT202021000001583

45A	Max Thickness	8 mm
70A	Max Thickness	12.5 mm
100A	Max Thickness	20.0 mm

35+
Years

TEC.MO.®

UPH-105

PLASMA CUTTING TORCHES

AIRONCUT®

**New high visibility consumable system
to cut inaccessible parts.**



35+
Years

TEC.MO.®

TH-70

PLASMA CUTTING TORCHES

AIRONCUT®

New high visibility consumable system
to cut inaccessible parts.

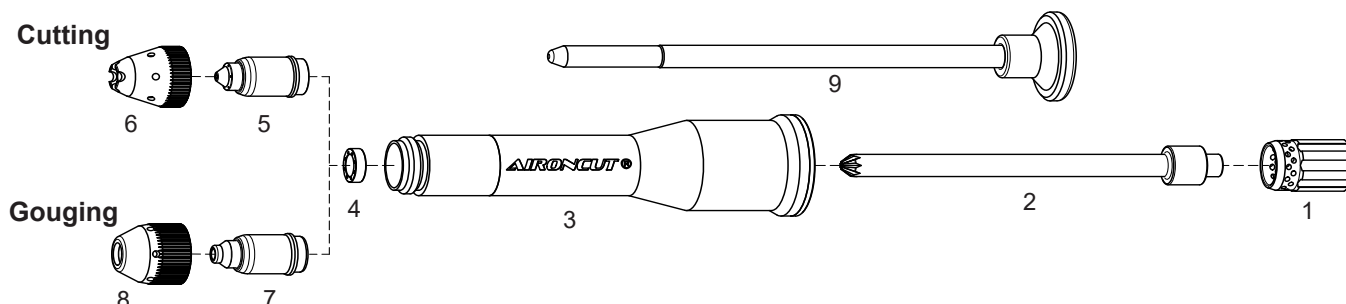

For gouging use maximum 4 bar

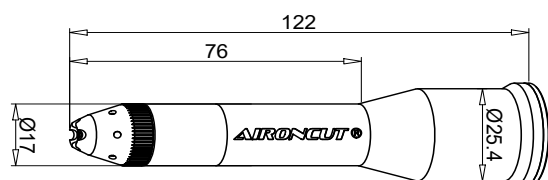

53052T Standard Kit 70A Cutting

#	Code	Description	Pkg
1	60041E	Swirl Ring 20-70A	2
2	53001	Electrode	3
3	53012T	Shield Cup Body	1
4	53022	Vortex Ring	3
5	53031	Tip 20-45A	5
	53032	Tip 70A	5
6	53047	Shield Cap Cutting	5
7	53036	Tip 50A Gouging	5
	53037	Tip 70A Gouging	5
8	53046	Shield Cap Gouging	5
9	53080	Extractor for tip	1

BXATH70-AC**BXATH70-AC****Special Box**

Code	Description	Qty
60041E	Swirl Ring 20-70A	1
53001	Electrode	2
53022	Vortex Ring	2
53031	Tip 20-45A	3
53032	Tip 70A	5
53047	Shield Cap Cutting	2
53036	Tip 50A Gouging	3
53037	Tip 70A Gouging	5
53046	Shield Cap Gouging	2
53052T	Standard Kit 70A Cutting	1

IT Util. Pat. Pend.:
N° IT202021000001583

45A Max Thickness 8 mm
70A Max Thickness 12.5 mm

35+
Years

TEC.MO.®

TH-70

PLASMA CUTTING TORCHES

AIRONCUT®

New high visibility consumable system
to cut inaccessible parts.



35+
Years

TEC.MO.®

TH-105

PLASMA CUTTING TORCHES

AIRONCUT®

New high visibility consumable system
to cut inaccessible parts.

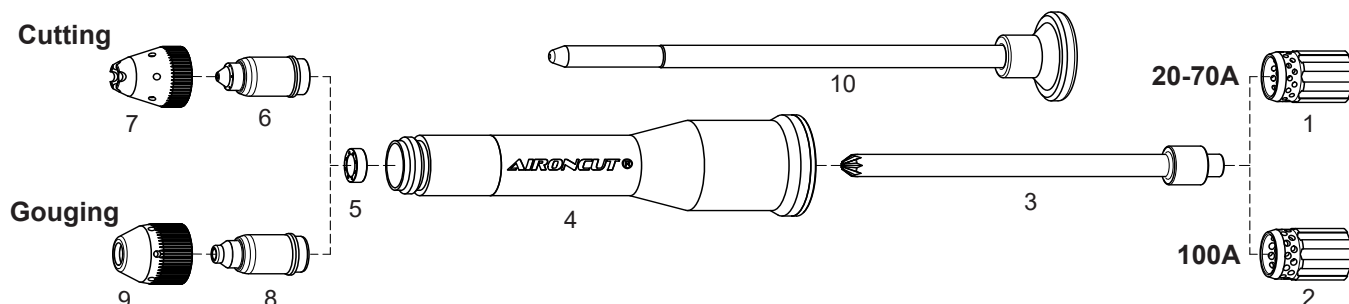

For gouging use maximum 4 bar

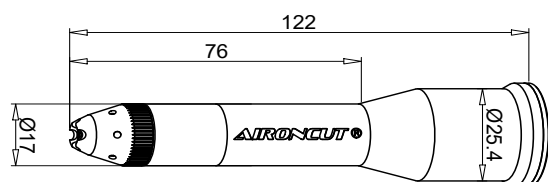
**53052T Standard Kit 70A Cutting**

#	Code	Description	Pkg
1	60041E	Swirl Ring 20-70A	2
2	60024E	Swirl Ring 100A	2
3	53001	Electrode	3
4	53012T	Shield Cup Body	1
5	53022	Vortex Ring	3
6	53031	Tip 20-45A	5
	53032	Tip 70A	5
	53034	Tip 100A	5
7	53047	Shield Cap Cutting	5
8	53036	Tip 50A Gouging	5
	53037	Tip 70A Gouging	5
	53038	Tip 100A Gouging	5
9	53046	Shield Cap Gouging	5
10	53080	Extractor for tip	1

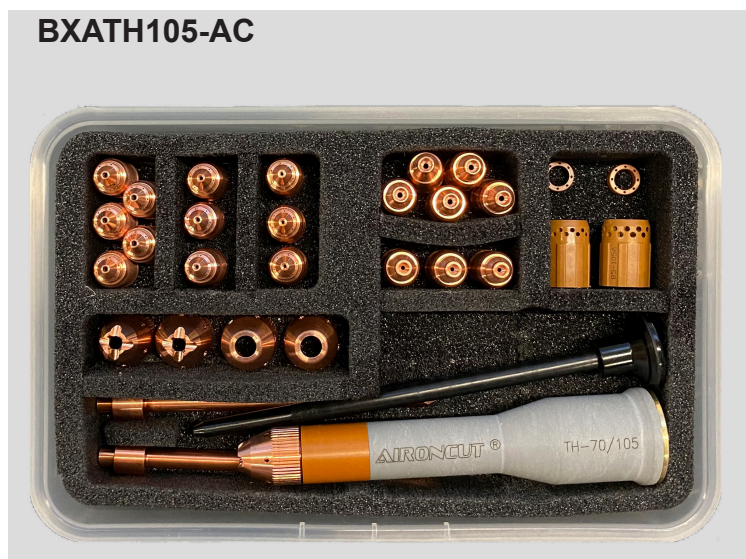
BXATH105-AC**BXATH105-AC****Special Box**

Code	Description	Qty
60041E	Swirl Ring 20-70A	1
60024E	Swirl Ring 100A	1
53001	Electrode	2
53022	Vortex Ring	2
53031	Tip 20-45A	3
53032	Tip 70A	3
53034	Tip 100A	5
53047	Shield Cap Cutting	2
53037	Tip 70A Gouging	3
53038	Tip 100A Gouging	5
53046	Shield Cap Gouging	2
53052T	Standard Kit 70A Cutting	1

IT Util. Pat. Pend.:
N° IT202021000001583

45A	Max Thickness	8 mm
70A	Max Thickness	12.5 mm
100A	Max Thickness	20.0 mm

35+
Years

TEC.MO.®

TH-105

PLASMA CUTTING TORCHES

AIRONCUT®

**New high visibility consumable system
to cut inaccessible parts.**



35+
Years

TEC.MO.®

UPH-125

PLASMA CUTTING TORCHES

AIRONCUT®

New high visibility consumable system
to cut inaccessible parts.

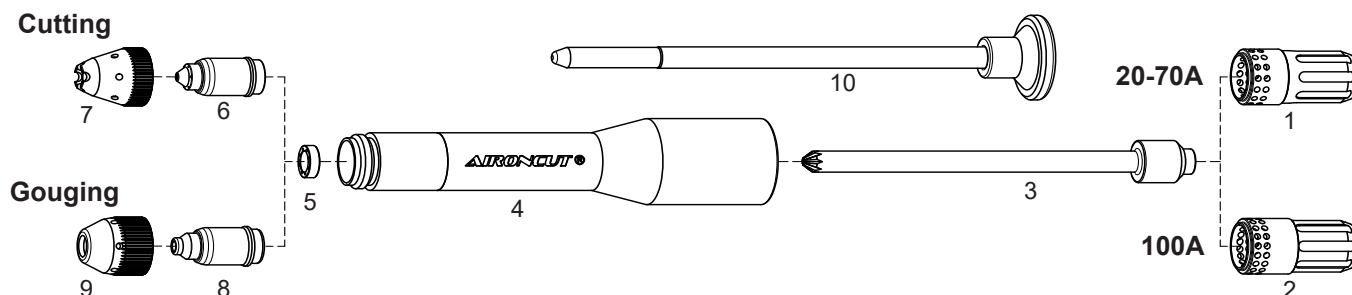

For gouging use maximum 4 bar

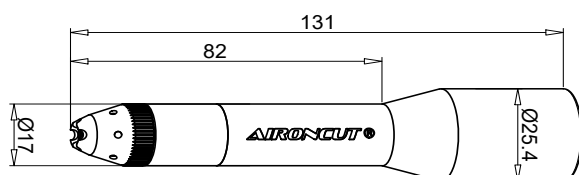

53152 Standard Kit 70A Cutting

#	Code	Description	Pkg
1	60042E	Swirl Ring 20-70A	2
2	60040E	Swirl Ring 100A	2
3	53101	Electrode	3
4	53112	Shield Cup Body	1
5	53022	Vortex Ring	3
6	53031	Tip 20-45A	5
	53032	Tip 70A	5
	53034	Tip 100A	5
7	53047	Shield Cap Cutting	5
8	53036	Tip 50A Gouging	5
	53037	Tip 70A Gouging	5
	53038	Tip 100A Gouging	5
9	53046	Shield Cap Gouging	5
10	53080	Extractor for tip	1

BXAUPH125-AC**BXAUPH125-AC****Special Box**

Code	Description	Qty
60042E	Swirl Ring 20-70A	1
60040E	Swirl Ring 100A	1
53101	Electrode	2
53022	Vortex Ring	2
53031	Tip 20-45A	3
53032	Tip 70A	3
53034	Tip 100A	5
53047	Shield Cap Cutting	2
53037	Tip 70A Gouging	3
53038	Tip 100A Gouging	5
53046	Shield Cap Gouging	2
53152	Standard Kit 70A Cutting	1

IT Util. Pat. Pend.:
N° IT202021000001583

45A	Max Thickness	8 mm
70A	Max Thickness	12.5 mm
100A	Max Thickness	20.0 mm

35+
Years

TEC.MO.®

UPH-125

PLASMA CUTTING TORCHES

AIRONCUT®

**New high visibility consumable system
to cut inaccessible parts.**



35+
Years

TEC.MO.®

TH-125

PLASMA CUTTING TORCHES

AIRONCUT®

New high visibility consumable system
to cut inaccessible parts.

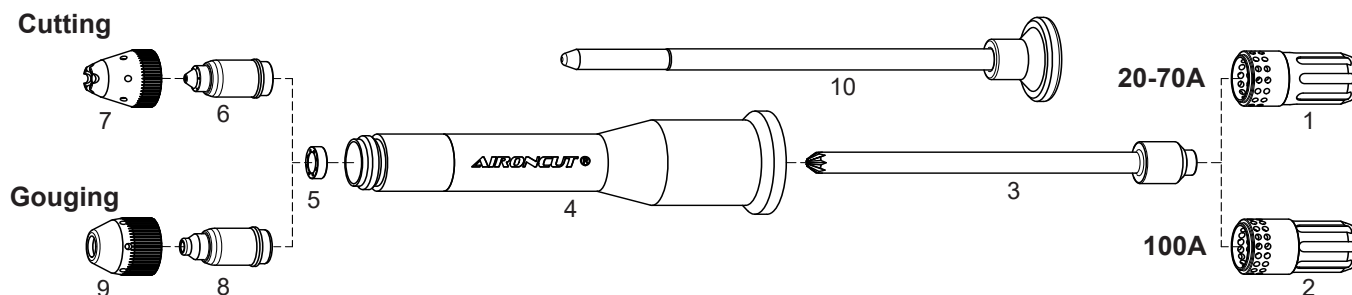

For gouging use maximum 4 bar

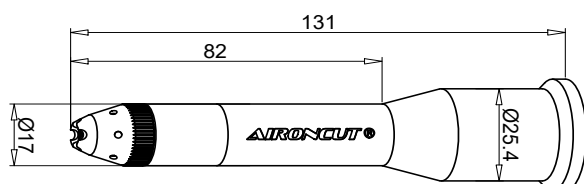
**53152T Standard Kit 70A Cutting**

#	Code	Description	Pkg
1	60042E	Swirl Ring 20-70A	2
2	60040E	Swirl Ring 100A	2
3	53101	Electrode	3
4	53112T	Shield Cup Body	1
5	53022	Vortex Ring	3
6	53031	Tip 20-45A	5
	53032	Tip 70A	5
	53034	Tip 100A	5
7	53047	Shield Cap Cutting	5
8	53036	Tip 50A Gouging	5
	53037	Tip 70A Gouging	5
	53038	Tip 100A Gouging	5
9	53046	Shield Cap Gouging	5
10	53080	Extractor for tip	1

BXATH125-AC**BXATH125-AC****Special Box**

Code	Description	Qty
60042E	Swirl Ring 20-70A	1
60040E	Swirl Ring 100A	1
53101	Electrode	2
53022	Vortex Ring	2
53031	Tip 20-45A	3
53032	Tip 70A	3
53034	Tip 100A	5
53047	Shield Cap Cutting	2
53037	Tip 70A Gouging	3
53038	Tip 100A Gouging	5
53046	Shield Cap Gouging	2
53152T	Standard Kit 70A Cutting	1

IT Util. Pat. Pend.:
N° IT202021000001583

45A	Max Thickness	8 mm
70A	Max Thickness	12.5 mm
100A	Max Thickness	20.0 mm

35+
Years

TEC.MO.®

TH-125

PLASMA CUTTING TORCHES

AIRONCUT®

New high visibility consumable system
to cut inaccessible parts.



35+
Years

TEC.MO.®

UPH-160

PLASMA CUTTING TORCHES

AIRONCUT®

New high visibility consumable system
to cut inaccessible parts.

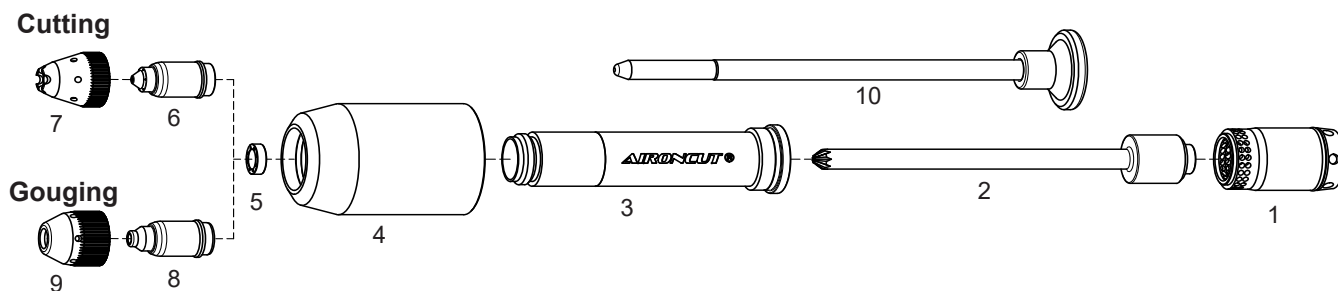

For gouging use maximum 4 bar

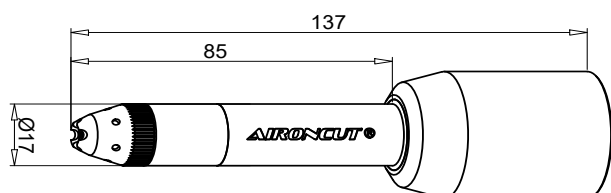

53252 Standard Kit 70A Cutting

#	Code	Description	Pkg
1	60039E	Swirl Ring	2
2	53201	Electrode	3
3	53211	Shield Cup Body	1
4	53212	Retaining Cap	1
5	53022	Vortex Ring	3
6	53031	Tip 20-45A	5
	53032	Tip 70A	5
	53034	Tip 100A	5
7	53047	Shield Cap Cutting	5
8	53036	Tip 50A Gouging	5
	53037	Tip 70A Gouging	5
	53038	Tip 100A Gouging	5
9	53046	Shield Cap Gouging	5
10	53080	Extractor for tip	1

BXAUPH160-AC**BXAUPH160-AC****Special Box**

Code	Description	Qty
60039E	Swirl Ring	1
53201	Electrode	2
53022	Vortex Ring	2
53031	Tip 20-45A	3
53032	Tip 70A	3
53034	Tip 100A	5
53047	Shield Cap Cutting	2
53037	Tip 70A Gouging	3
53038	Tip 100A Gouging	5
53046	Shield Cap Gouging	2
53252	Standard Kit 70A Cutting	1

IT Util. Pat. Pend.:
N° IT202021000001583

45A	Max Thickness	8 mm
70A	Max Thickness	12.5 mm
100A	Max Thickness	20.0 mm

35+
Years

TEC.MO.®

UPH-160

PLASMA CUTTING TORCHES

AIRONCUT®

**New high visibility consumable system
to cut inaccessible parts.**



35+
Years

TEC.MO.®

UPH-70/105

PLASMA CUTTING TORCHES

AIRONCUT XXXL®

New high visibility consumable system
to cut inaccessible parts.

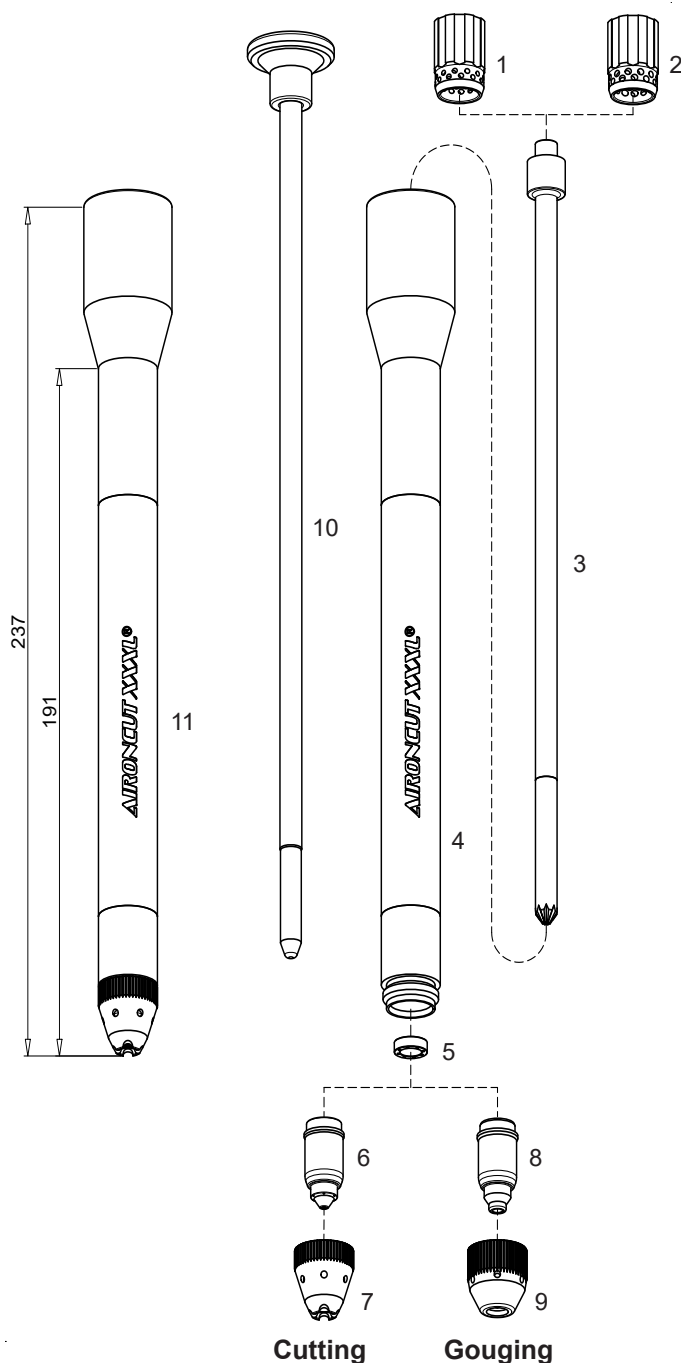

#	Code	Description	Pkg
1	60041E	Swirl Ring 20-70A	2
2	60024E	Swirl Ring 100A	2
3	53001L	Electrode **	3
4	53012L	Shield Cup Body	1
5	53022	Vortex Ring	3
6	53031	Tip 20-45A	5
	53032	Tip 70A	5
	53034	Tip 100A	5
7	53047	Shield Cap 20-100A	5
8	53036	Tip 50A Gouging	5
	53037	Tip 70A Gouging	5
	53038	Tip 100A Gouging	5
9	53046	Shield Cap Gouging	5
10	53080L	Extractor for tip	1
11	53052L	Complete Kit 70A Cutting	1



** Item not saleable in USA and Russia, being patented in said country.

Tec.Mo. accepts no responsibility in case of its customer's attempted sale in USA and Russia.



53052L Standard Kit 70A Cutting

IT Util. Pat. Pend.:
N° IT202021000001583

For gouging use maximum 4 bar

45A	Max Thickness	8 mm
70A	Max Thickness	12.5 mm
100A	Max Thickness	20.0 mm

35+
Years

TEC.MO.®

UPH-70/105

PLASMA CUTTING TORCHES

AIRONCUT XXXL®

**New high visibility consumable system
to cut inaccessible parts.**



35+
Years

TEC.MO.®

UPH-160

PLASMA CUTTING TORCHES

AIRONCUT XXXL®

New high visibility consumable system
to cut inaccessible parts.

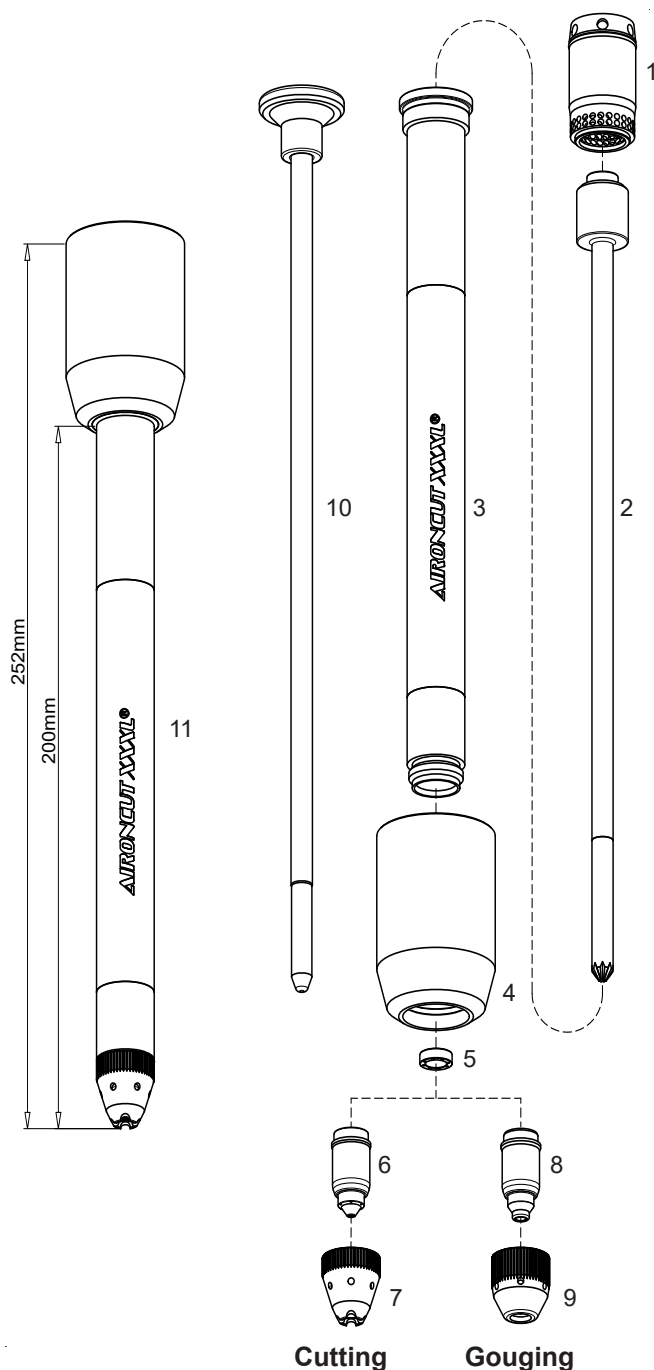

#	Code	Description	Pkg
1	60039E	Swirl Ring	2
3	53201L	Electrode **	3
4	53211L	Shield Cup Body	1
5	53212	Retaining Cap	1
5	53022	Vortex Ring	3
6	53031	Tip 20-45A	5
	53032	Tip 70A	5
	53034	Tip 100A	5
7	53047	Shield Cap 20-100A	5
8	53036	Tip 50A Gouging	5
	53037	Tip 70A Gouging	5
	53038	Tip 100A Gouging	5
9	53046	Shield Cap Gouging	5
10	53080L	Extractor for tip	1
11	53252L	Complete Kit 70A Cutting	1



** Item not saleable in USA and Russia, being patented in said country.

Tec.Mo. accepts no responsibility in case of its customer's attempted sale in USA and Russia.



53252L Standard Kit 70A Cutting

IT Util. Pat. Pend.:
N° IT202021000001583

For gouging use maximum 4 bar

45A	Max Thickness	8 mm
70A	Max Thickness	12.5 mm
100A	Max Thickness	20.0 mm

35+
Years

TEC.MO.®

UPH-160

PLASMA CUTTING TORCHES

AIRONCUT XXXL®

**New high visibility consumable system
to cut inaccessible parts.**



35+
Years

TEC.MO.®

PT-40/60

PLASMA CUTTING TORCHES

AIRONCUT®

New high visibility consumable system
to cut inaccessible parts.

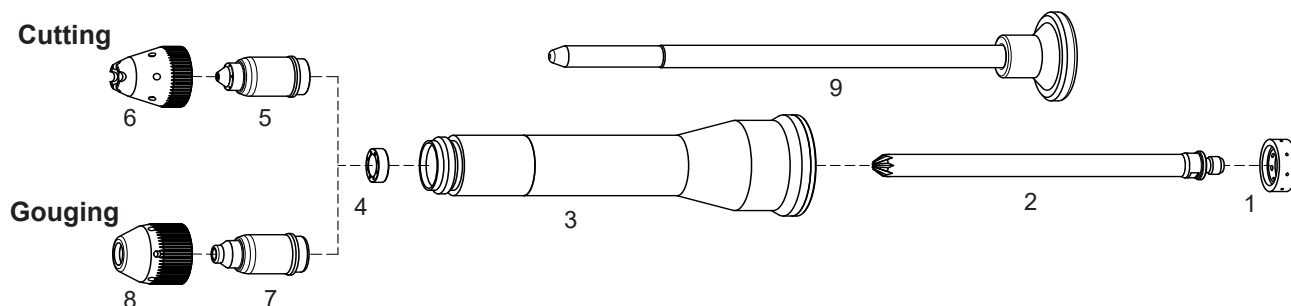

For gouging use maximum 4 bar

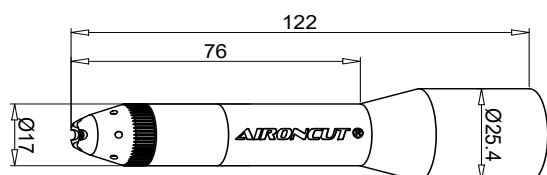

53050 Standard Kit 40A Cutting
Packaging containing ✕

#	Code	Description	Pkg
1	53023 ✕	Swirl Ring 20-70A	2
2	53002 ✕	Electrode	3
3	53010 ✕	Shield Cup Body	1
4	53022 ✕	Vortex Ring	3
5	53031 ✕	Tip 20-45A	5
	53032	Tip 60A	5
6	53047 ✕	Shield Cap Cutting	5
7	53036	Tip 50A Gouging	5
8	53046	Shield Cap Gouging	5
9	53080 ✕	Extractor for tip	1

BXAPT60-AC**BXAPT60-AC****Special Box**

Code	Description	Qty
53023	Swirl Ring 20-60A	1
53002	Electrode	2
53022	Vortex Ring	1
53031	Tip 20-45A	3
53032	Tip 60A	3
53047	Shield Cap Cutting	1
53036	Tip 50A Gouging	3
53046	Shield Cap Gouging	1
53050	Standard Kit 40A Cutting	1

IT Util. Pat. Pend.:
N° IT202021000001583

60A Max Thickness 10 mm

35+
Years

TEC.MO.®

PT-40/60

PLASMA CUTTING TORCHES

AIRONCUT®

**New high visibility consumable system
to cut inaccessible parts.**

