

FLATCUT®

with 45 degree inclined arc for cutting Flat

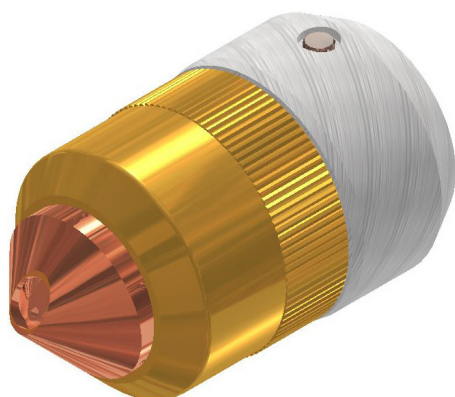

#	Code	Description	Pkg
	53501	Standard KIT 40-70A	1
1	60075	Swirl Ring 40-70A	2
2	53519	Electrode 40-70A	5
3	53510	Retaining Cap	1
4	53530	Tip 40/70A	5
5	53541	Retaining Ring	2
	53502	Standard KIT 80-105A	1
6	60076	Swirl Ring 80-105A	2
7	53520	Electrode 80-105A	5
3	53510	Retaining Cap	1
8	53531	Tip 80-105A	5
5	53541	Retaining Ring	2

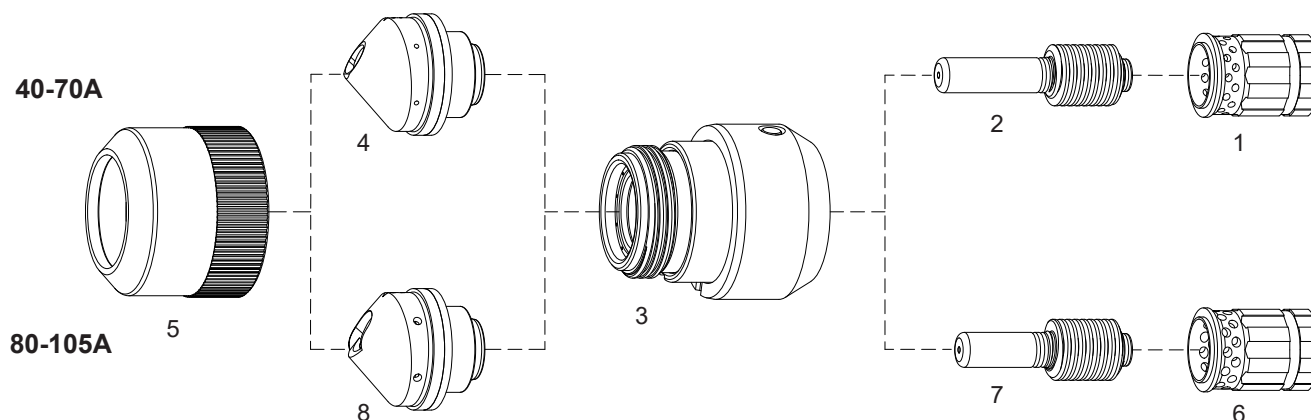
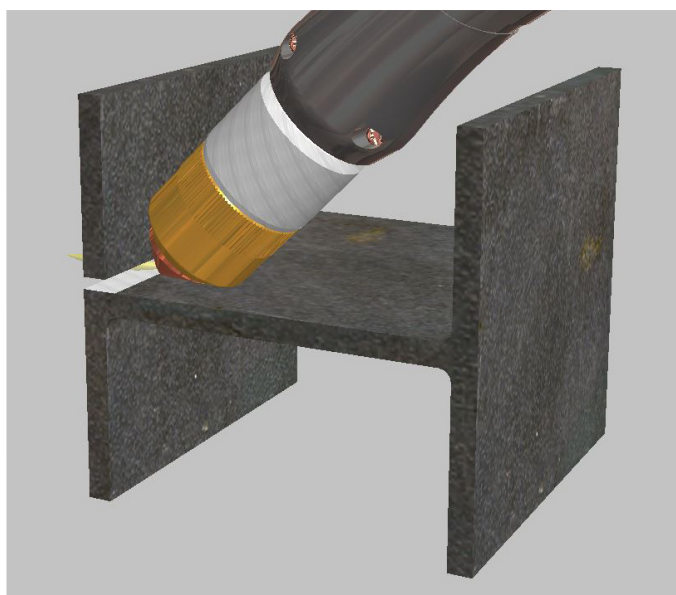

FLATCUT®

Some cutting examples that can be performed
with the FLATCUT

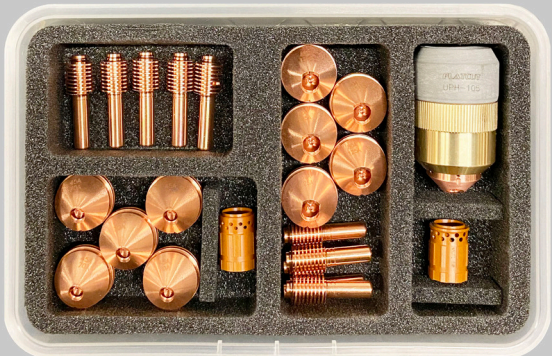
BXAUPH105-FC**BXAUPH105-FC Special Box**

Code	Description	Qty
60075	Swirl Ring 40-70A	1
53519	Electrode 40-70A	5
53530	Tip 40-70A	5
60076	Swirl Ring 80-105A	1
53520	Electrode 80-105A	5
53531	Tip 80-105A	5
53502	Standard KIT 80-105A	1

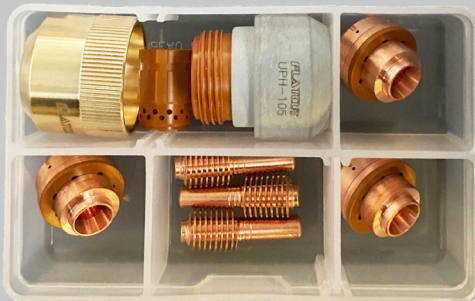
BXDUPH70-FC**BXDUPH70-FC Mini Kit 40-70A**

Code	Description	Qty
60075	Swirl Ring 40-70A	1
53519	Electrode 40-70A	3
53510	Retaining Cap	1
53530	Tip 40-70A	3
53541	Retaining Ring	1

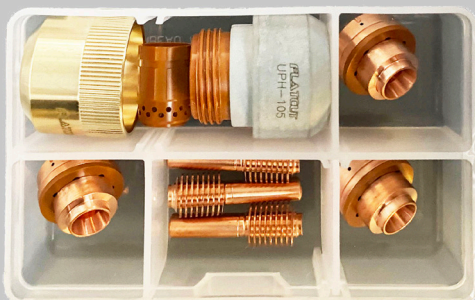
BXDUPH105-FC**BXDUPH105-FC Mini Kit 80-105A**

Code	Description	Qty
60076	Swirl Ring 80-105A	1
53520	Electrode 80-105A	3
53510	Retaining Cap	1
53531	Tip 80-105A	3
53541	Retaining Ring	1